

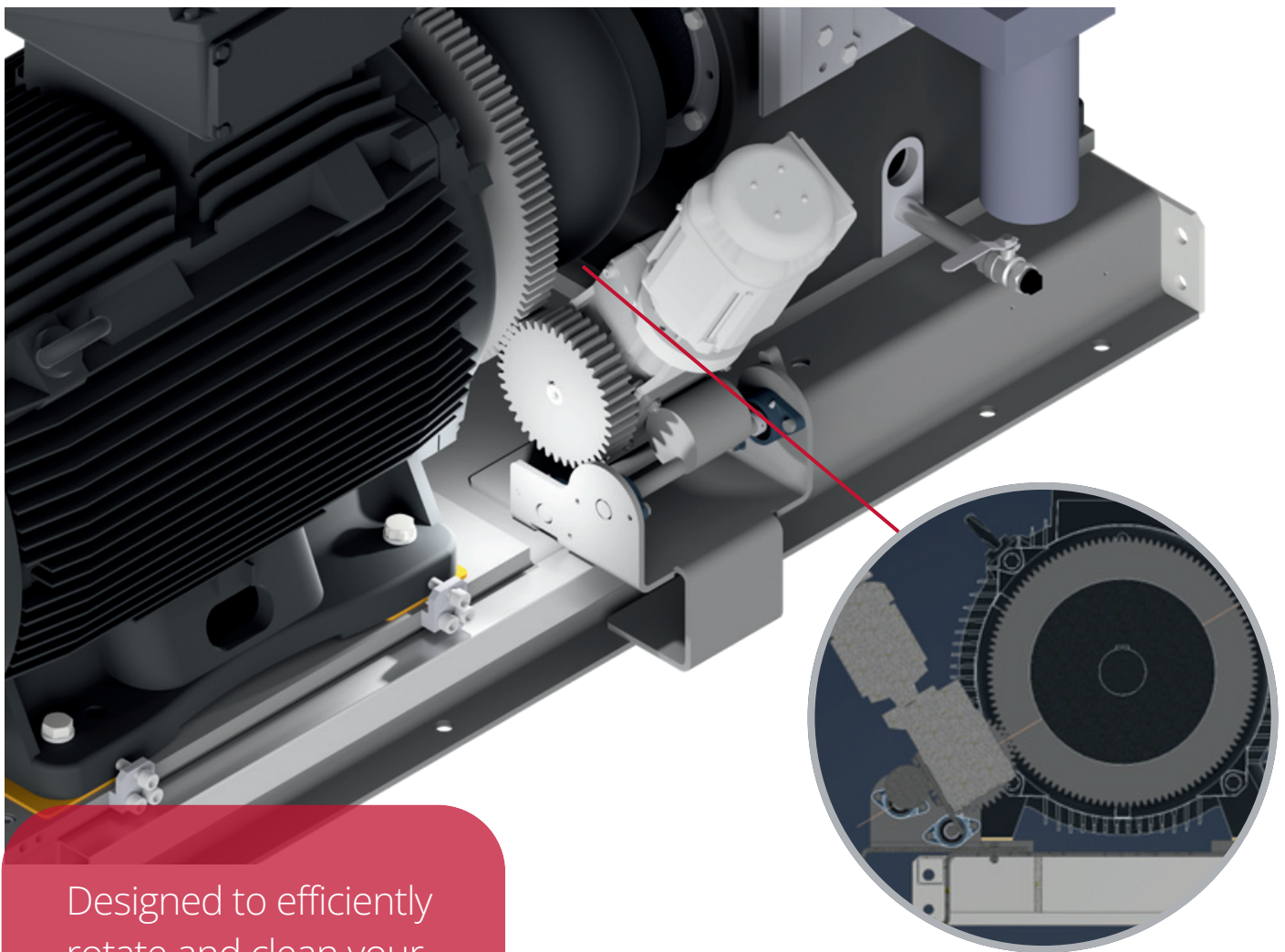

## Slow Drive 7900 Series

ONECPM.COM

The Slow Drive 7900 Series is retrofit solution for your Pellet Mill, designed to enable controlled, low-speed operation while the pellet chamber remains open. This innovative tool allows reverse rotation for thorough internal die cleaning, streamlining roll re-adjustment and minimizing downtime.



CONTACT@ONECPM.COM

Designed to efficiently rotate and clean your CPM Pellet Mill dies—while maintaining safety procedures.

### Includes:

- Gear on the main motor
- New Coupling Guard
- Slow Drive Components
- Control Components

# Slow Drive **7900 Series**

## Operation Parts

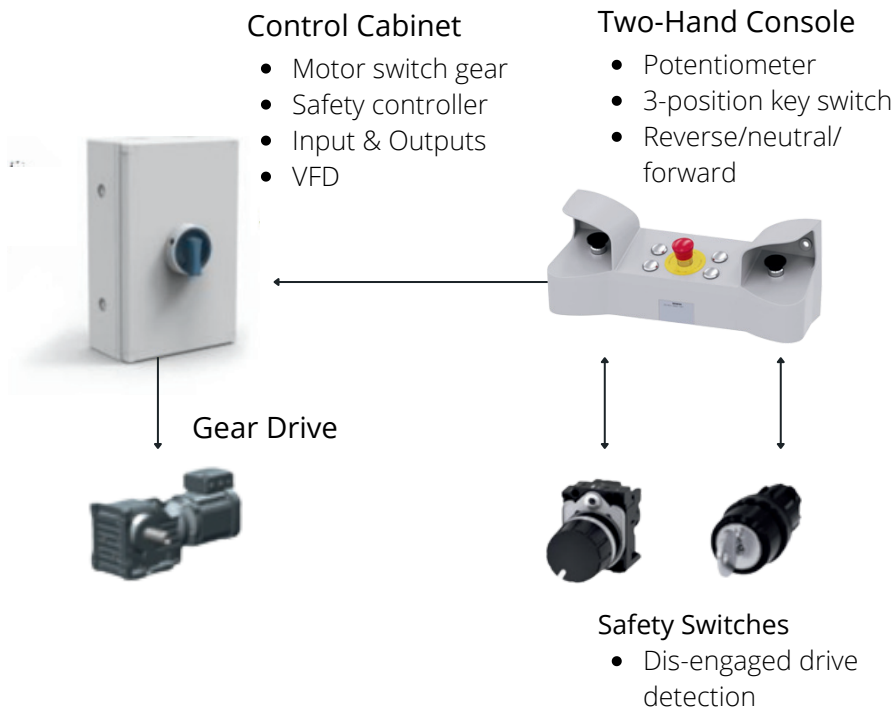

## Safety Features

- Slow start
- E-stop

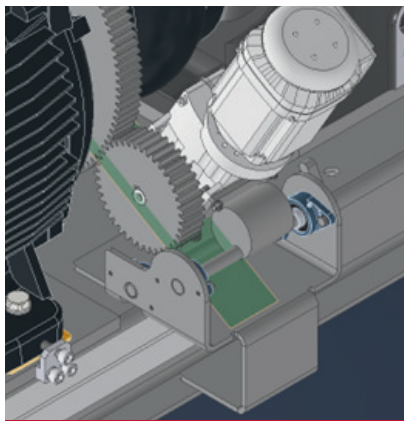

*Slow drive in operation*

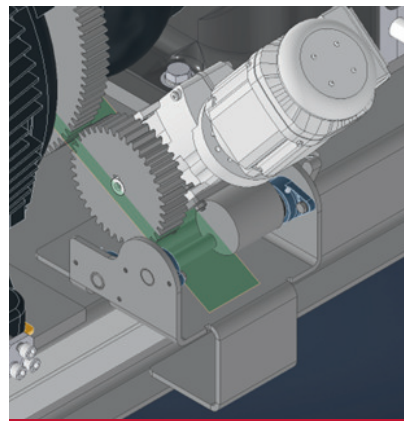

*Slow drive out of operation*

## Die Drive Characteristics

- Rotates the die in two directions
- Operates at a standard rotational speed of 4 RPM
- Delivers 2000 Nm of torque directly at the die

The Slow Drive 7900 Series has been carefully developed and tested by our team of experts at our Innovation Center in Zaandam, Netherlands. Please contact your CPM representative to find out more about the Slow Drive 7900 Series.



From the food you eat to the fuels you require, CPM plays an important role in building a better world. Our experienced team and family of trusted brands are working together to make our planet a better place to live.

[CONTACT@ONECPM.COM](mailto:CONTACT@ONECPM.COM)  
[ONECPM.COM](http://ONECPM.COM)